

TH GRV-VD / VB BOOSTERS



General Information

High pressure, quiet running, compact and low power consumption.

GRV-VD / VB pumps are suitable for pumping non-abrasive, clean or slightly contaminated, low viscosity without solid & fibrous particles liquids.

Vertical structure saves space.

Technical Data

Capacity _____ up to 60 m³ /h

Head _____ up to 170 m

Casing Pressure _____ 10-16-25 bar

Operating Temperature _____ up to 50 °C

Design Features

- TH GRV-VD / VB boosters are manufactured with vertical pump.
- The boosters are produced as single, double and triple pumps as a standard according to the desired flow. Upon request, up to 6 pumps can be set.
- Single-pump boosters have a water level float (electric floater).
- Phase control system (PCS) is available in single pump, three-phase motorized boosters.
- Sequencing, phase control and liquid level control are standard features for multiple pumped booster pumps.
- Booster pumps can operate in two different modes; automatically and manually.

Booster Designation

TH 1 x GRV-VD 5

Booster Type _____

Number of Pumps _____

Pump Type _____

Number of Stage _____

- Electric motors of high efficiency class conforming to IEC 60034-30 standard are used.
- The booster pumps can be manufactured as a variable-speed frequency control for convenience. (upon request)

Material Information

Part Name	Material	
	Standard	Optional
Pump		
Base Plate	GG 25	Bronz / AISI 304
Stage Casing	NORYL	Bronz / AISI 304
Intermediate Stage	NORYL	Bronz / AISI 304
Impeller	NORYL	Bronz / AISI 304
Shaft	AISI 420	AISI 304
Cover Plate	AISI 304	-
Panel	Pressure Switch Controlled	Frequency Controlled
Collector	Galvanized Steel	AISI 304
Frame	Fabricated Steel	Galvanized Steel
Accessories		
Valve	Brass	AISI 304
Check Valve	Brass	AISI 316

Performance Curve and Dimension Charts

TH GRV-VD / VB

Pump Type	Motor		Dimensions (mm)																
	kW	IEC	A	B	B(max)	Ka	Kb	h	d	h1	h2	KG							
1 x GRV-VD 3	1.5	90S	430	300	480	410	240	740	R1½"	135	265	70							
1 x GRV-VD 4	2.2	90L						780			305	75							
1 x GRV-VD 5	3	100L						820			345	85							
1 x GRV-VD 6	4	112M						860			386	100							
1 x GRV-VD 7	4							900			427	105							
1 x GRV-VD 8	5.5							940			467	125							
1 x GRV-VD 9	5.5	132S						980			507	130							
1 x GRV-VD 10	7.5							1020			547	135							
2 x GRV-VD 3	1.5	90S						520			730	760	500	580	1075	R2"	170	300	160
2 x GRV-VD 4	2.2	90L													1075			340	165
2 x GRV-VD 5	3	100L	1075	380	185														
2 x GRV-VD 6	4	112M	1075	420	210														
2 x GRV-VD 7	4		1075	460	215														
2 x GRV-VD 8	5.5		1075	500	260														
2 x GRV-VD 9	5.5	132S	1125	540	270														
2 x GRV-VD 10	7.5		1365	580	275														
3 x GRV-VD 3	1.5	90S	790	730	780	770	580		1175	R2½"					140			300	230
3 x GRV-VD 4	2.2	90L							1175									340	240
3 x GRV-VD 5	3	100L						1175	380		270								
3 x GRV-VD 6	4	112M						1275	420		305								
3 x GRV-VD 7	4							1275	460		315								
3 x GRV-VD 8	5.5							1325	500		390								
3 x GRV-VD 9	5.5	132S						1375	540		395								
3 x GRV-VD 10	7.5							1500	580		405								

Dimensions might be changed.

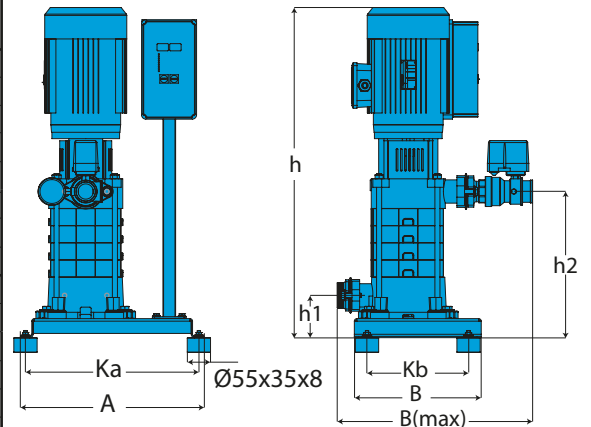

Booster set with one pump

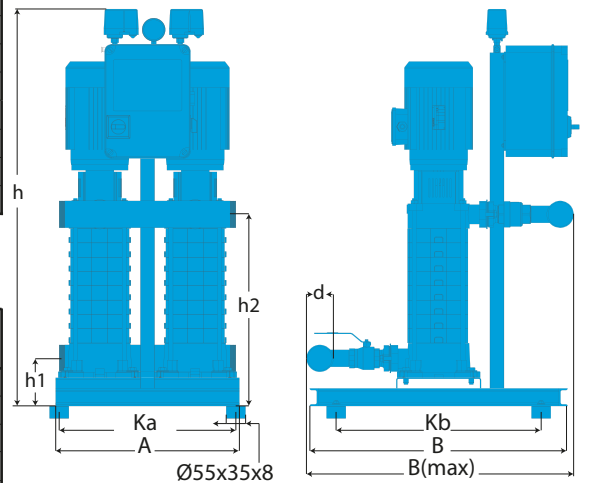

Booster set with two pump

Pump Type	Motor		Dimensions(mm)																
	kW	IEC	A	B	B(max)	Ka	Kb	h	d	h1	h2	KG							
1 x GRV-VB 3	2.2	90L	435	300	465	410	240	740	R2"	100	265	70							
1 x GRV-VB 4	3	100L						780			305	75							
1 x GRV-VB 5	4	112M						820			345	85							
1 x GRV-VB 6	5.5	132S						860			386	100							
1 x GRV-VB 7	5.5							900			427	105							
1 x GRV-VB 8	7.5							940			467	125							
1 x GRV-VB 9	7.5	160M						980			507	130							
1 x GRV-VB 10	11							1020			547	135							
2 x GRV-VB 3	2.2	90L						520			730	760	500	580	1075	R2½"	135	300	160
2 x GRV-VB 4	3	100L													1075			340	165
2 x GRV-VB 5	4	112M	1075	380	185														
2 x GRV-VB 6	5.5	132S	1075	420	210														
2 x GRV-VB 7	5.5		1075	460	215														
2 x GRV-VB 8	7.5		1075	500	260														
2 x GRV-VB 9	7.5	160M	1125	540	270														
2 x GRV-VB 10	11		1365	580	275														
3 x GRV-VB 3	2.2	90L	790	750	780	770	580		1175	R3"					135			300	230
3 x GRV-VB 4	3	100L							1175									340	240
3 x GRV-VB 5	4	112M						1175	380		270								
3 x GRV-VB 6	5.5	132S						1275	420		305								
3 x GRV-VB 7	5.5							1275	460		315								
3 x GRV-VB 8	7.5							1325	500		390								
3 x GRV-VB 9	7.5	160M						1375	540		395								
3 x GRV-VB 10	11							1500	600		405								

Dimensions might be changed.

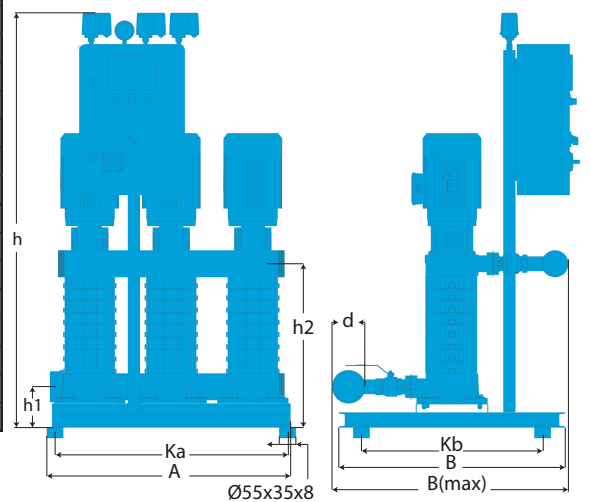

Booster set with three pump

GRV-VD

$n_s = 2900 \text{ rpm}$

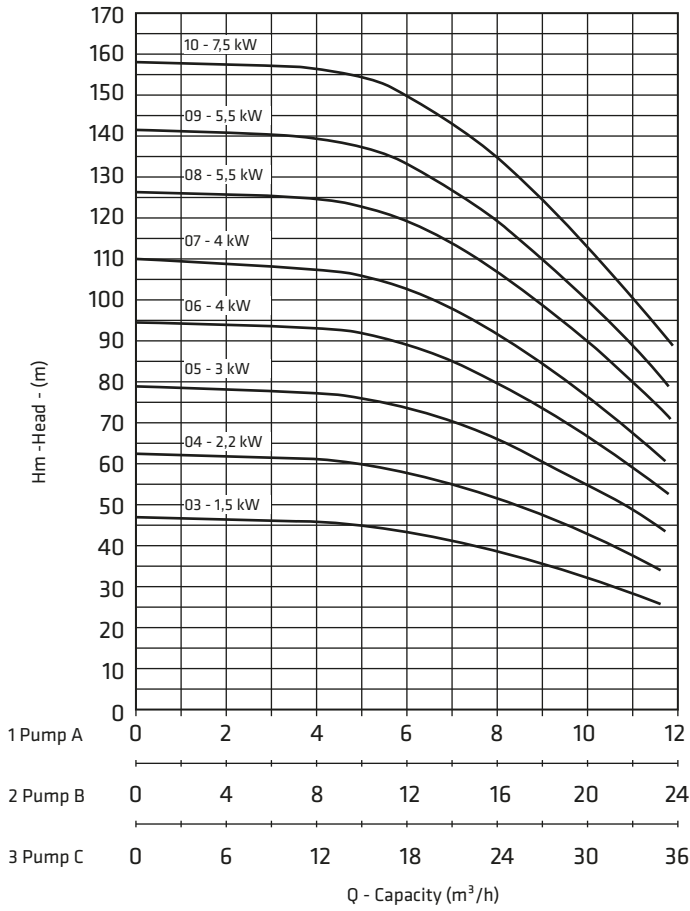

GRV-VB

$n_s = 2900 \text{ rpm}$

