



Pump • Fire Fighting Units • Booster Set

ECO SNMV-H

VERTICAL CENTRIFUGAL PUMPS



ECO SNMV-H Rev.05 03.2024

Handled Liquids

Clean or slightly contaminated low viscosity liquids without solid & fibrous particles.

Technical Data

Discharge Flange _____ DN 32.....DN 250 mm

Capacity _____ up to 1200 m³/h(*)

Head _____ up to 160 m(*)

Speed _____ up to 3600 rpm(*)

Design Temperature _____ -10 °C' to +140 °C(**)

Casing Pressure (Pmax) _____ 10 bar (16 bar)(**)

(Pmax: Suction Pressure + Shut off Head)

(*) The Material of pumps differ according to the type of pumped liquid, operating temperature and pressure. Contact for detailed information.

Design Features

•Vertical, radially split volute casing type, single stage, end suction centrifugal pump with closed impeller.

•Suction and discharge flanges conform to EN 1092-2 / PN 16.

Pump Designation

Pump Type _____

Discharge Nozzle (DN-mm) _____

Nominal Impeller Diameter (mm) _____



•Due to the back-pull-out design, the complete bearing assembly including impeller and casing cover can be dismantled without removing the volute casing from the pipe system. With spacer coupling application, also possible to take out the rotor group without dismantling the electric motor.

•All impellers are balanced dynamically or statically according to ISO 1940 class 6.3.

•Axial thrust is balanced by impeller balancing holes system.

•Direction of rotation is clockwise viewed from drive end.

•Bearings of ECO SNMV-H type pumps are life time greased lubricated ball bearings.

Shaft Sealing

•In standard production mechanical seals are used according to pumped liquid and working conditions.

ECO SNMV-H 125 - 315

1450 rpm

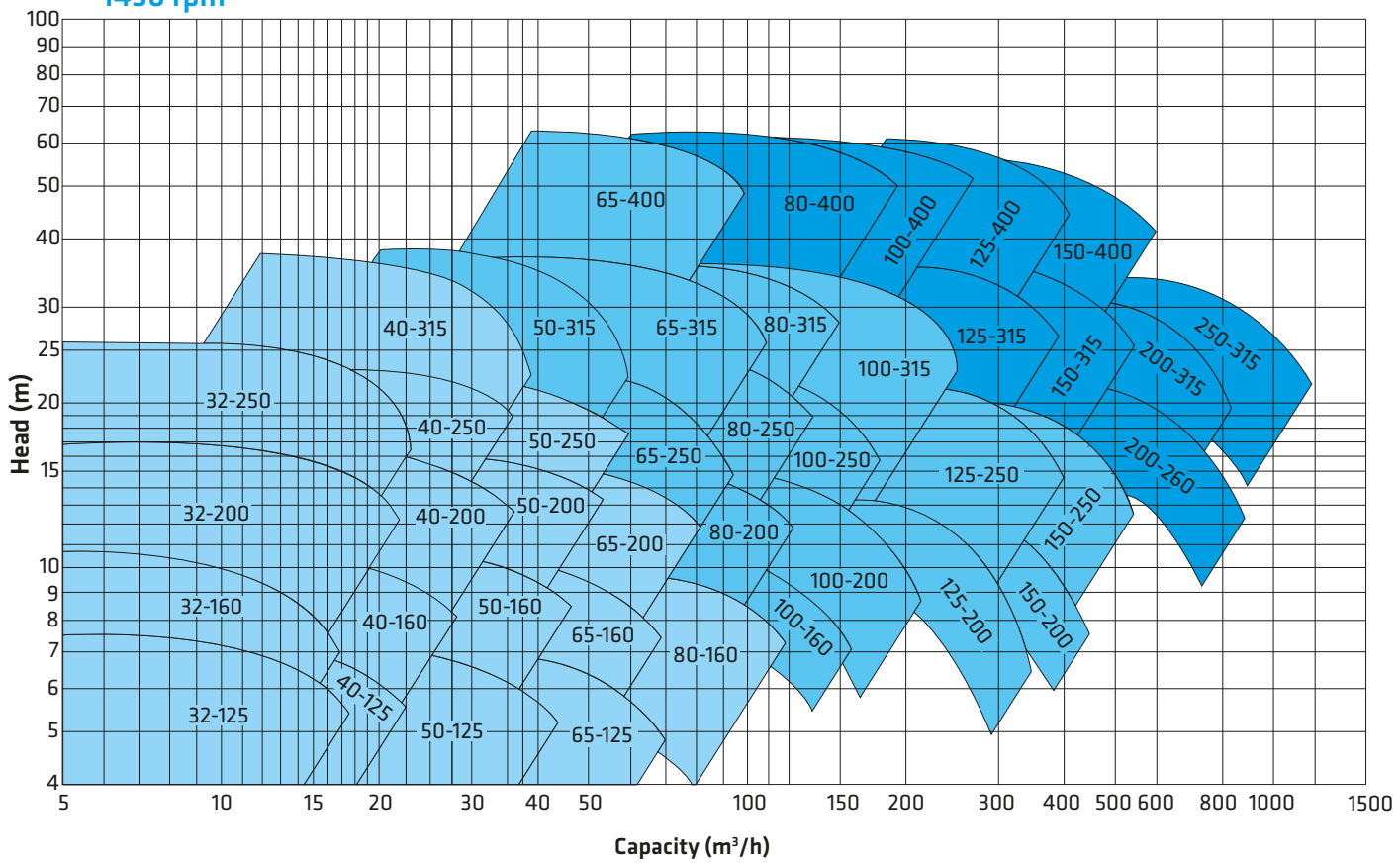

2900 rpm

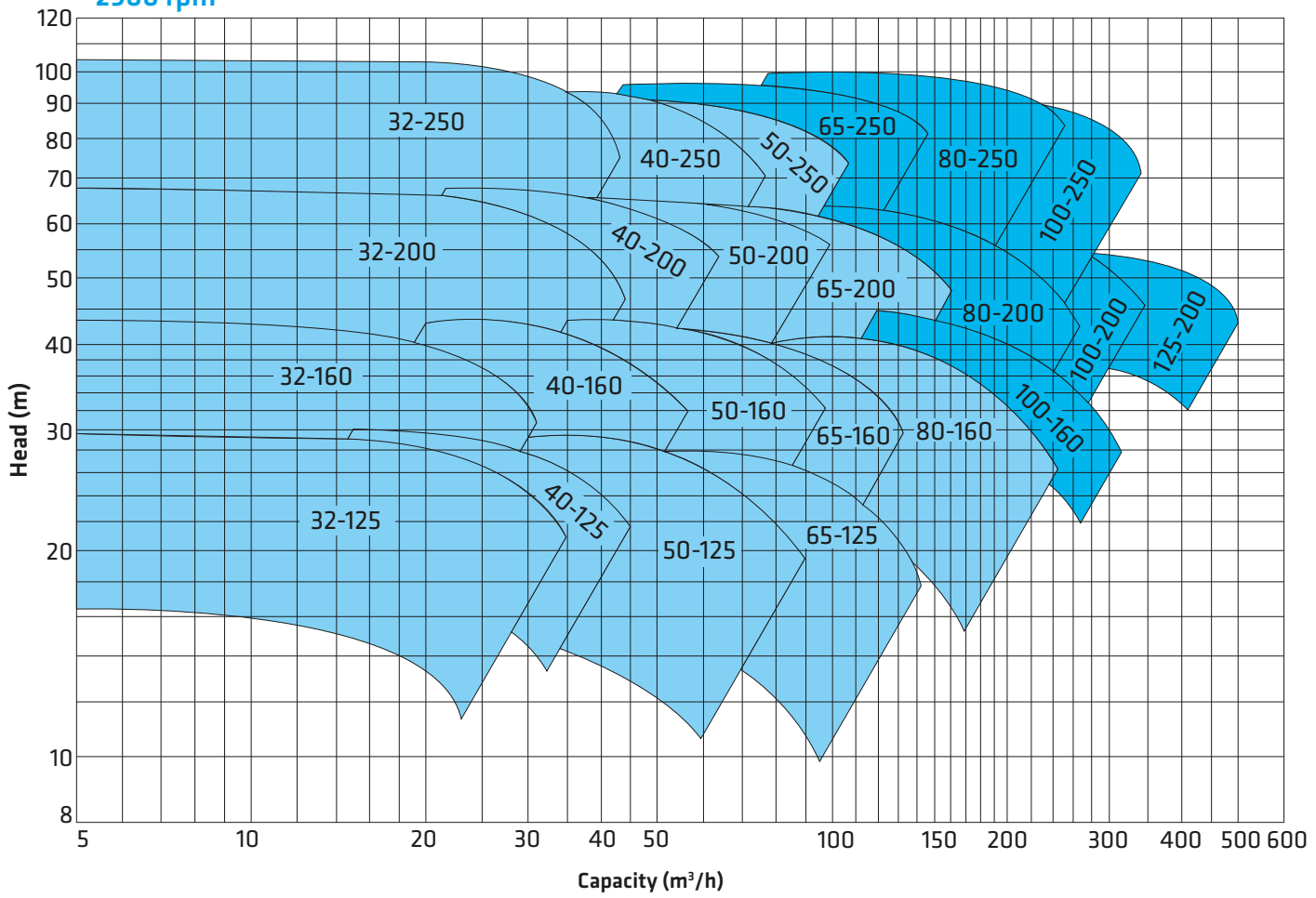

Part List

001	Volute Casing
005	Motor Pedestal
006	Motor Spacer Flange
010	Pump Foot
011	Suction Elbow
020*	Wear Ring (Casing)
021*	Wear Ring (Seal Cover)
030	Bearing Housing
034	Bearing Cover
043	Mechanical Seal Cover
049	Mechanical Seal Spacer Sleeve
050	Impeller
060	Pump Shaft
065	Impeller Nut
085	Coupling
088	Thrower
200	Ball Bearing
210	Impeller Key
211	Coupling Key
230	Drain Plug
405	Mechanical Seal
420	O-Ring
550	Guard
551	Coupling Guard
600	Electric Motor

(*) Optional

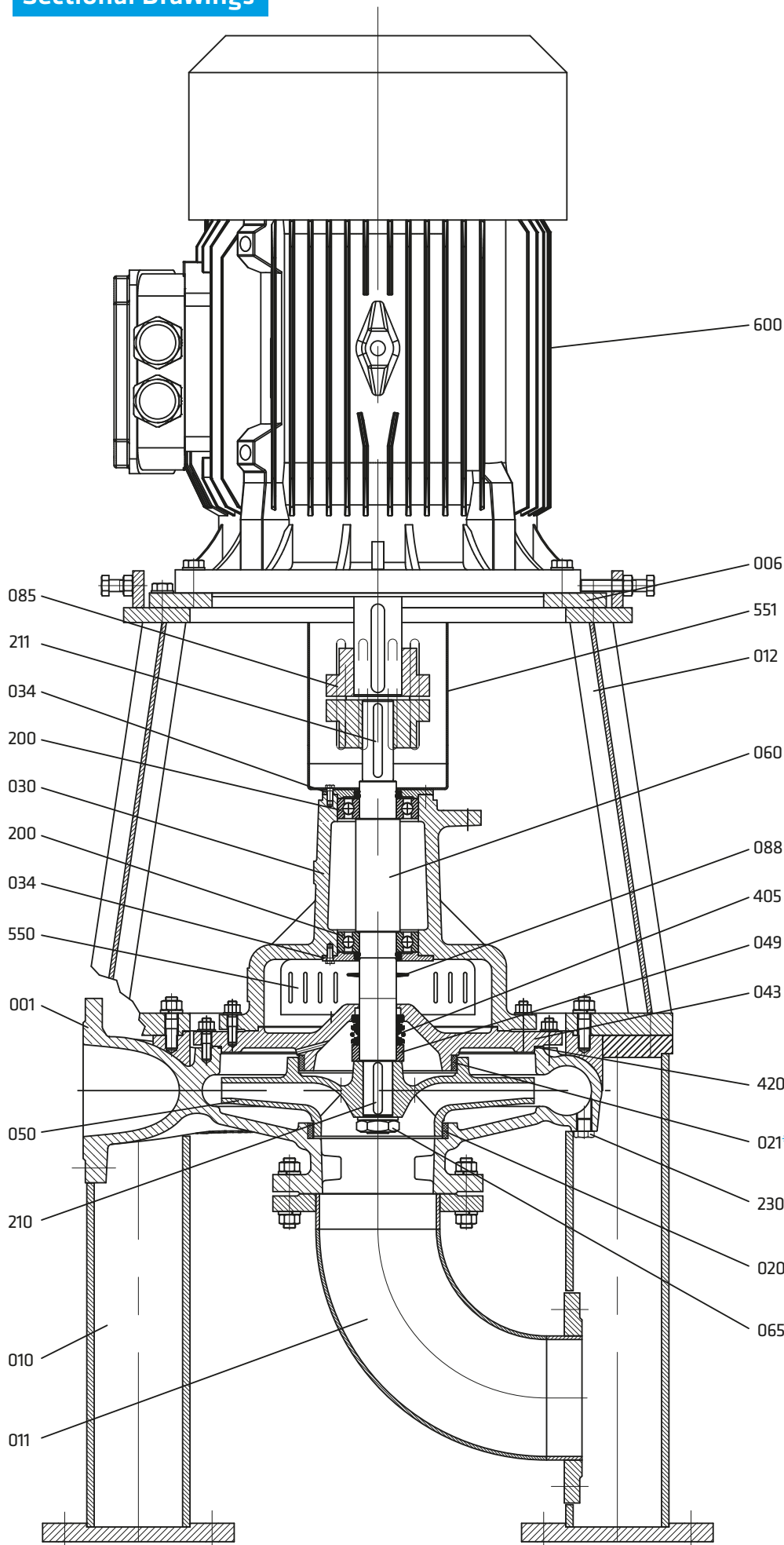

Material Options

Part List	10	30	35	20	60	6L	70	7L	8M	7D	7S	8N	80	4C	4A	40	80	8T	60	7L	7E	7D	
	0.6025	0.7040	0.7043	1.0619	1.4308	1.4309	1.4408	1.4409	1.4500	1.4517	1.4469	1.4317	1.4008	2.1050.01	2.0975.01	2.1096.01	1.4021	1.4021+QT	1.4301	1.4404	1.4460	1.4462	
Volute Casing	●	○	○	○	○	○	○	○	○	○	○	○	○	○									
Casing Cover	●	○	○	○	○	○	○	○	○	○	○	○	○	○									
Impeller	●	○	○	○	○	○	○	○	○	○	○	○	○	○	○	○						○	
Shaft																	●	○	○	○			○
Bearing Housing	●	○	○	○	○	○	○	○															
Mechanical Seal(*)	EN 12756																						

(*) Optional: Depending on customer requirement or request different types and brands of mechanical seals are applicable.

● Standard manufacturing
○ Optional

Material Equivalents

Description	DIN / EN		AISI / SAE / ASTM
Cast Iron	0.6025	EN-GJL-250 (GG25)	A48 Class 40B
Nodular Cast Iron	0.7040	EN-GJS-400-15 (GGG40)	A536 60-40-18
Nodular Cast Iron	0.7043	EN-GJS-400-18-LT (GGG40.3)	A536 60-40-18
Cast Steel	1.0619	GP240GHGS-C25	A216 WCB
Chrome Nickel Cast Steel	1.4308	GX5CrNi19-10	A351 CF8
Chrome Nickel Cast Steel (low carbon)	1.4309	GX2CrNi19-11	A351 CF3
Chrome Nickel Molybdenum Cast Steel	1.4408	GX5CrNiMo19-11-2	A351 CF8M
Chrome Nickel Molybdenum Cast Steel (low carbon)	1.4409	GX2CrNiMo19-11-2	A351 CF3M
Austenitic Cast Steel	1.4500	GX7NiCrMoCuNb25-20	A351 CN7M
Austenitic - Ferritic Cast Steel (duplex)	1.4517	GX2CrNiMoCuN25-6-3-3	A890 CD4MCuN
Austenitic - Ferritic Cast Steel (super duplex)	1.4469	GX2CrNiMoN26-7-4	A890 CE3MN
Martenzitic Stainless Cast Steel	1.4317	GX4CrNi13-4	A352 CA6NM
Martenzitic Stainless Cast Steel	1.4008	GX7CrNiMo12-1	A217 CA15
Cast Bronze (tin alloy)	2.1050.01	G-CuSn10	B427 C90700
Cast Bronze (nickel alloy)	2.0975.01	G-CuAl10Ni	B148 C95500
Cast Bronze (lead)	2.1096.01	G-CuSn5ZnPb	B584 C83600
Chrome Steel	1.4021	X20Cr13	A276 Type 420
Chrome Steel(heat treated)	1.4021	X20Cr13	A276 Type 420+QT
Chrome Nickel Steel	1.4301	X5CrNi18-10	A276 Type 304
Chrome Nickel Steel (low carbon)	1.4404	X2CrNiMo17-12-2	A276 Type 316L
Duplex (austenitic-ferritic) Steel	1.4460	X3CrNiMoN27-5-2	AISI 329
Duplex (austenitic-ferritic) Steel	1.4462	X2CrNiMoN22-5-3	UNS S32205

Flange Dimensions

EN 1092 - 2	DNe/DNb	Suction & Discharge (PN 16)			
		Df	k	s	n
	32	140	100	18	4
	40	150	110	18	4
	50	165	125	18	4
	65	185	145	18	4
	80	200	160	18	8
	100	220	180	18	8
	125	250	210	18	8
	150	285	240	22	8
	200	340	295	22	12
	250	405	355	26	12
	300	460	410	26	12

" n " number of holes

