



Pump • Fire Fighting Units • Booster Set

# ECO SKY

## THERMAL OIL PUMPS

ECO SKY Rev.05 03.2024

### Handled Liquids

Heat transfer oil or low viscosity industrial oil without aggressive solid particles.

### Technical Data

Discharge Flange \_\_\_\_\_ DN 32.....DN 150 mm

Capacity \_\_\_\_\_ up to 550 m<sup>3</sup>/h\*

Head \_\_\_\_\_ up to 105 m\*

Design Temperature \_\_\_\_\_ up to 350 °C

Cooling Method \_\_\_\_\_ With Air

Casing Pressure (Pmax) \_\_\_\_\_ 10 bar (16 bar)\*\*

(Pmax: Suction Pressure + Shut off Head)

(\*) Contact company for higher capacity and head values.

(\*\*) The Material of pump differs according to the type of pumped liquid, operating temperature and pressure. Contact for detailed information.

### Design Features

- Horizontal, radially split volute casing type, single stage, end suction, air cooled centrifugal pumps with closed impeller.
- Main dimensions conform to EN 733 standard.
- Suction and discharge flanges conform to EN 1092-2 / PN 16.
- Due to the back-pull-out design, the complete bearing assembly including impeller and casing cover can be dismantled without removing the volute casing from the pipe system. With spacer coupling application, also possible to take out the rotor group without dismantling the electric motor.

### Pump Designation

Pump Type \_\_\_\_\_

Discharge Nozzle (DN-mm) \_\_\_\_\_

Nominal Impeller Diameter (mm) \_\_\_\_\_



- All impellers are balanced dynamically according to ISO 1940 class 6.3.
- Axial thrust is balanced by impeller balancing holes system.
- Direction of rotation is clockwise viewed from drive end.
- Bearings of ECO SKY type pumps are “grease lubricated” ball bearings.

### Shaft Sealing

- High temperature resistant mechanical seals are used.

### Pressure & Temperature Limits

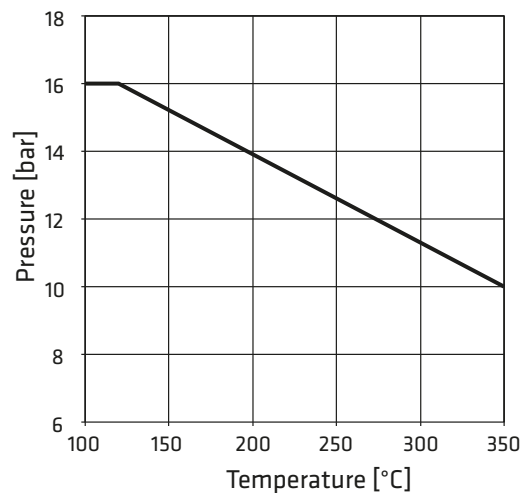

## ECO SKY 100 - 250

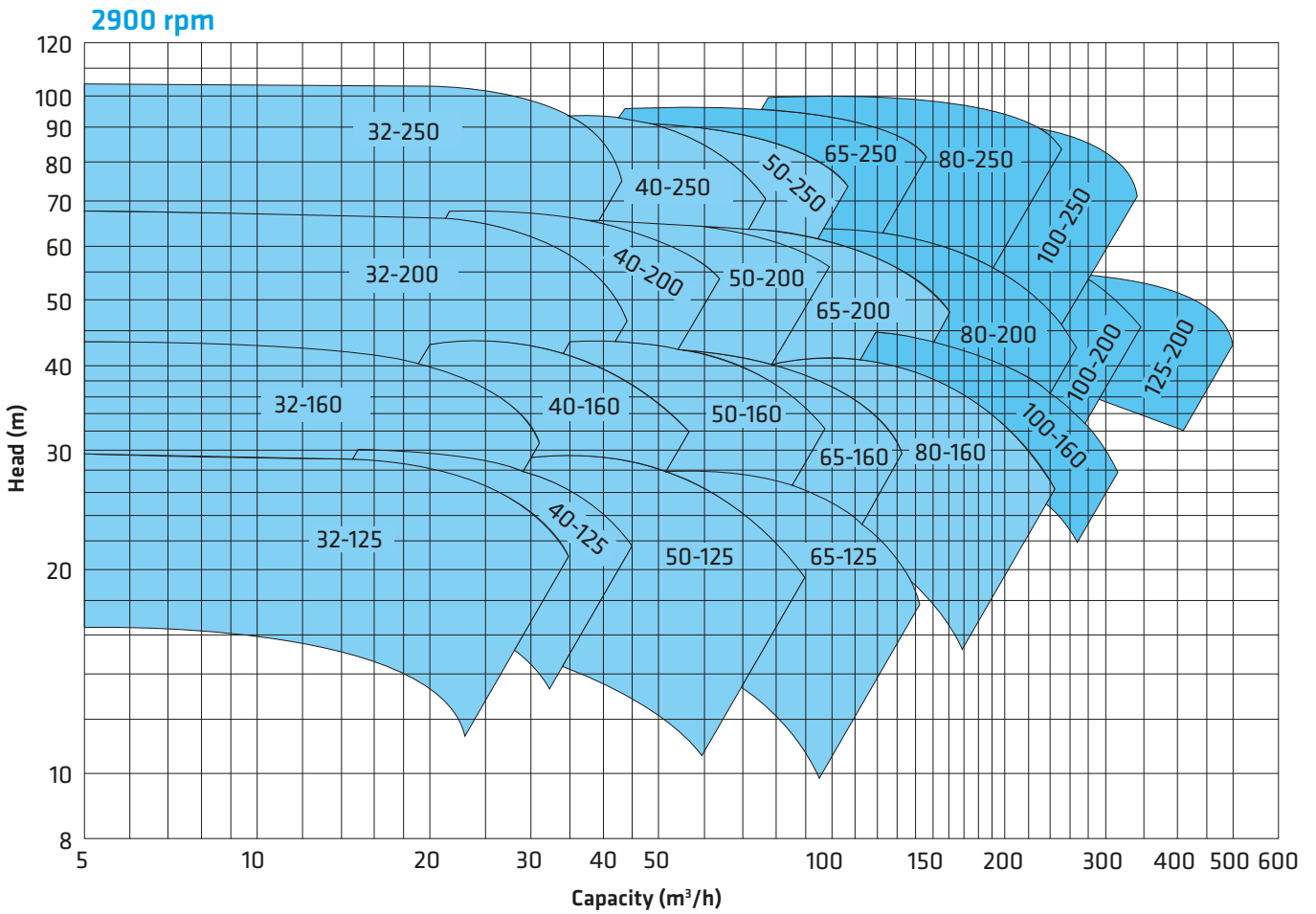
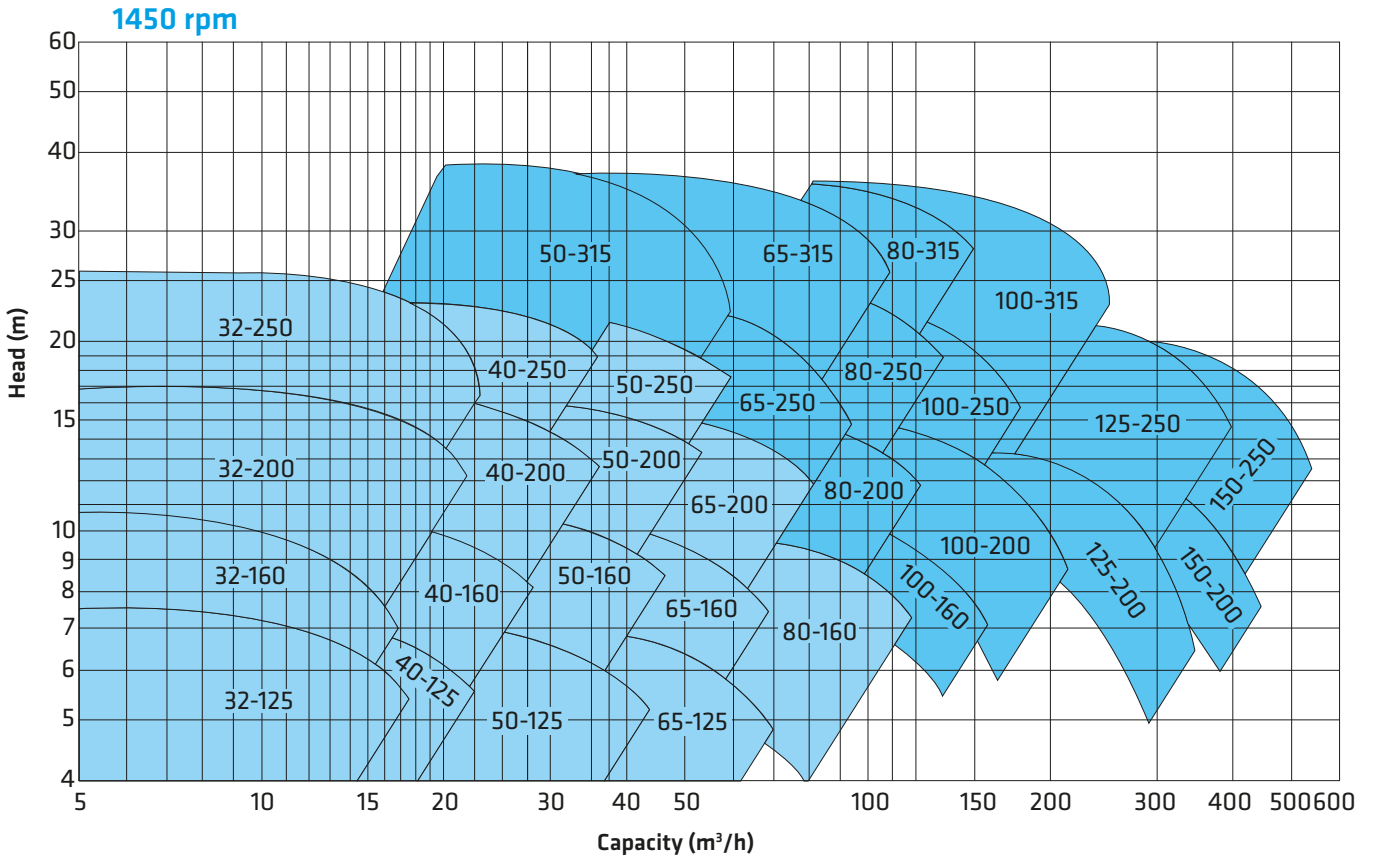

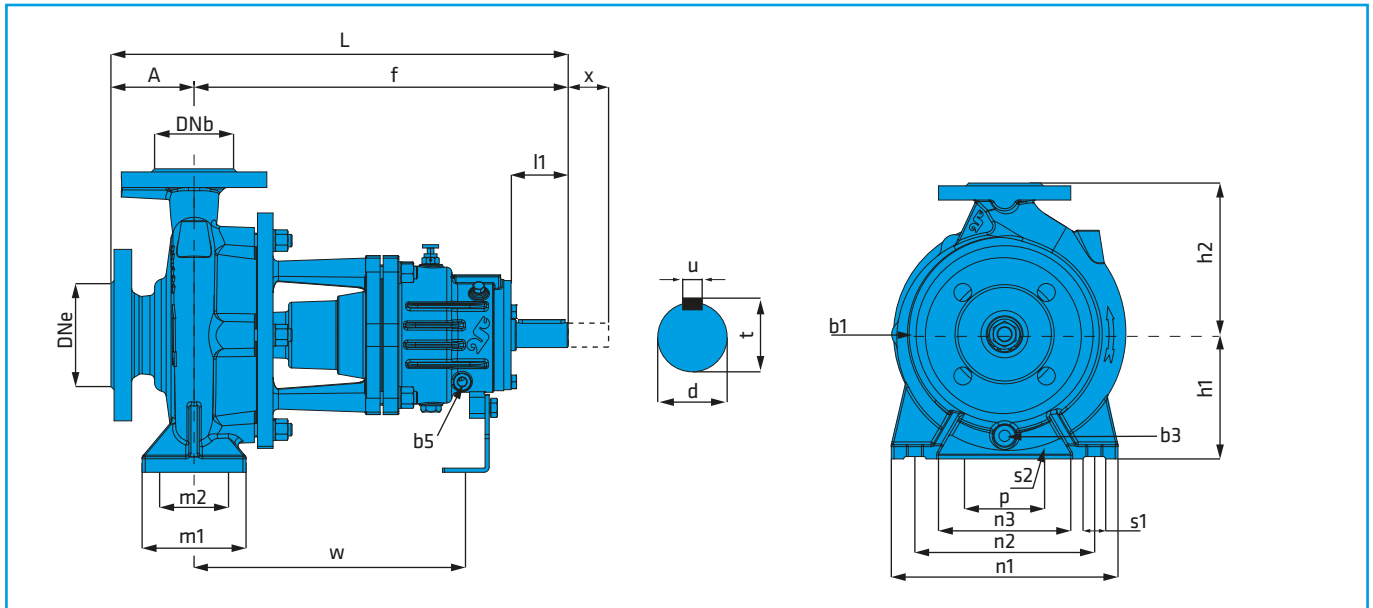

Pump Type		DIMENSIONS (mm)																Weight	Spacer						
		Overall Dimensions						Support & Foot Dimensions						Shaft End			Auxiliary Connections		(kg)	x*					
EN 733	Other	DNe	DNb	A	f	L	h1	h2	m1	m2	n1	n2	n3	s1	p	s2	w	d	l1	t	u	b3	b5		
32-125		50	32	80	360	440	112	140	100	70	190	140	90	14	110	14	260	24	50	27	8	1/4"	3/8"	32	100
32-160		50	32	80	360	440	132	160	100	70	240	190	140	14	110	14	260	24	50	27	8	1/4"	3/8"	39	100
32-200		50	32	80	360	440	160	180	100	70	240	190	140	14	110	14	260	24	50	27	8	1/4"	3/8"	41	100
	32-250	50	32	100	360	460	180	225	125	95	320	250	190	14	110	14	260	24	50	27	8	1/4"	3/8"	53	100
40-125		65	40	80	360	440	112	140	100	70	210	160	110	14	110	14	260	24	50	27	8	1/4"	3/8"	33	100
40-160		65	40	80	360	440	132	160	100	70	240	190	140	14	110	14	260	24	50	27	8	1/4"	3/8"	40	100
40-200		65	40	100	360	460	160	180	100	70	265	212	165	14	110	14	260	24	50	27	8	1/4"	3/8"	45	100
40-250		65	40	100	360	460	180	225	125	95	320	250	190	14	110	14	260	24	50	27	8	1/4"	3/8"	57	100
50-125		65	50	100	360	460	132	160	100	70	240	190	140	14	110	14	260	24	50	27	8	1/4"	3/8"	34	100
50-160		65	50	100	360	460	160	180	100	70	265	212	165	14	110	14	260	24	50	27	8	1/4"	3/8"	42	100
50-200		65	50	100	360	460	160	200	100	70	265	212	165	14	110	14	260	24	50	27	8	1/4"	3/8"	48	100
50-250		65	50	100	360	460	180	225	125	95	320	250	190	14	110	14	260	24	50	27	8	1/4"	3/8"	57	100
	50-315	65	50	125	470	595	225	280	125	95	345	280	190	19	110	14	340	32	80	35	10	1/4"	3/8"	90	100
65-125		80	65	100	360	460	160	180	125	95	280	212	150	14	110	14	260	24	50	27	8	3/8"	3/8"	40	100
65-160		80	65	100	360	460	160	200	125	95	280	212	150	14	110	14	260	24	50	27	8	3/8"	3/8"	46	100
65-200		80	65	100	360	460	180	225	125	95	320	250	190	14	110	14	260	24	50	27	8	3/8"	3/8"	51	140
65-250		80	65	100	470	570	200	250	160	120	360	280	200	19	110	14	340	32	80	35	10	3/8"	3/8"	90	140
65-315		80	65	125	470	595	225	280	160	120	400	315	240	19	110	14	340	32	80	35	10	3/8"	3/8"	105	140
80-160		100	80	125	360	485	180	225	125	95	320	250	190	14	110	14	260	24	50	27	8	3/8"	3/8"	49	140
80-200		100	80	125	470	595	180	250	125	95	345	280	215	14	110	14	340	32	80	35	10	3/8"	3/8"	63	140
80-250		100	80	125	470	595	200	280	160	120	400	315	240	19	110	14	340	32	80	35	10	3/8"	3/8"	95	140
80-315		100	80	125	470	595	250	315	160	120	400	315	240	19	110	14	340	32	80	35	10	3/8"	3/8"	125	140
	100-160	125	100	125	470	595	200	280	160	120	360	280	200	19	110	14	340	32	80	35	10	3/8"	3/8"	80	140
100-200		125	100	125	470	595	200	280	160	120	360	280	200	19	110	14	340	32	80	35	10	3/8"	3/8"	87	140
100-250		125	100	140	470	610	225	280	160	120	400	315	240	19	110	14	340	32	80	35	10	3/8"	3/8"	100	140
100-315		125	100	140	470	610	250	315	160	120	400	315	240	19	110	14	340	32	80	35	10	3/8"	3/8"	130	140
	125-200	150	125	140	470	610	250	315	160	120	400	315	240	19	110	14	340	32	80	35	10	1/2"	3/8"	97	140
125-250		150	125	140	470	610	250	355	160	120	400	315	240	19	110	14	340	32	80	35	10	1/2"	3/8"	110	140
	150-200	200	150	160	470	630	280	355	200	150	500	400	300	23	110	14	340	32	80	35	10	1/2"	3/8"	116	140
	150-250	200	150	160	470	630	280	375	200	150	500	400	300	23	110	14	340	32	80	35	10	1/2"	3/8"	132	140

(\*) Gap necessary for the withdrawal of the pump rotor from the driven end without the need for dismantling the motor and pipework (spacer coupling application)

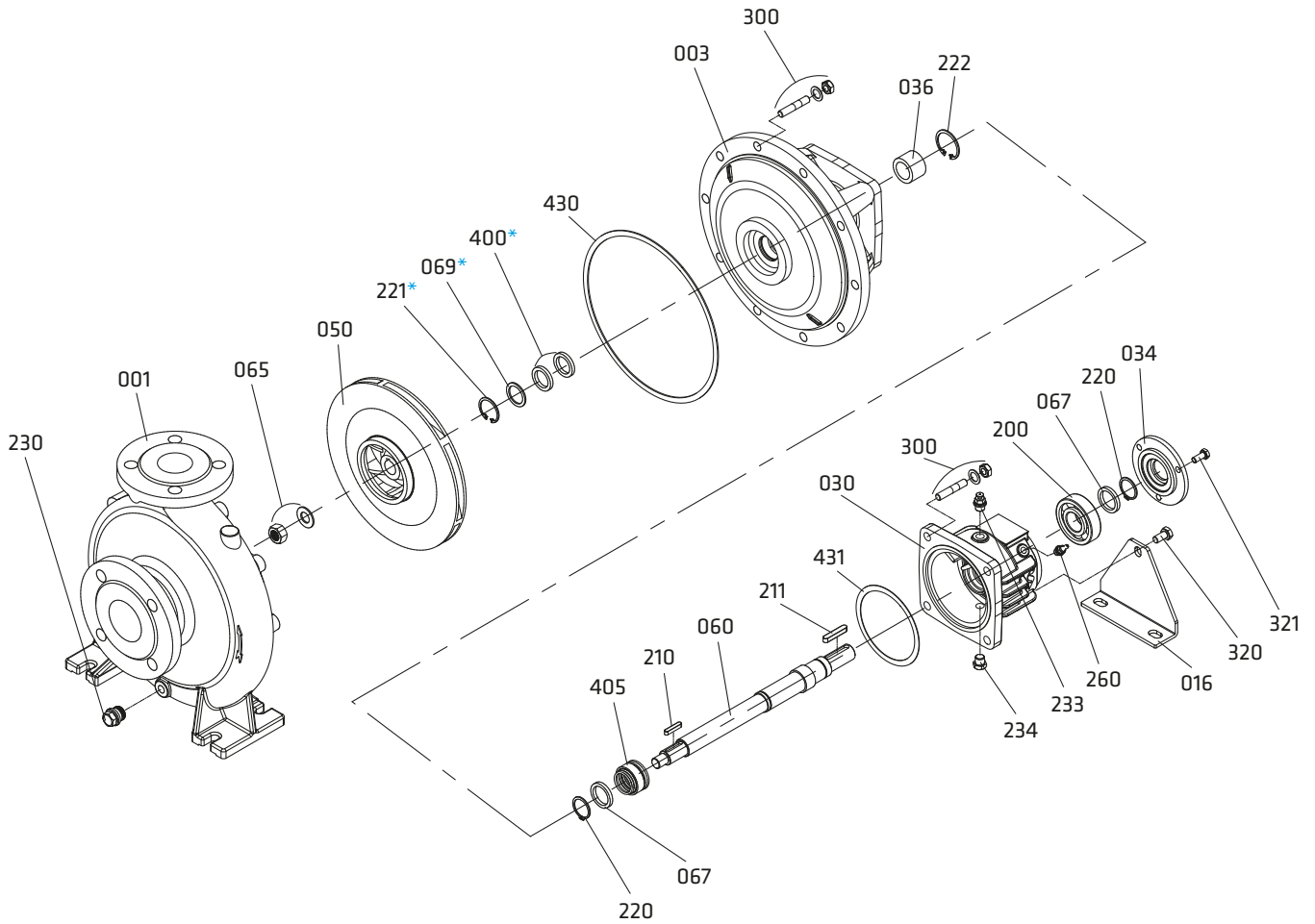

Part List

001	Volute Casing	221*	Circlip
003	Casing Cover	230	Screw
016	Support Foot	233	Breather
030	Bearing Housing	234	Screw
034	Bearing Cover	260	Grease Nipple
036	Sleeve Bearing	300	Stud Bolt, Washer and Nut
050	Impeller	320	Screw
060	Shaft	321	Screw
065	Impeller Nut and Washer	400*	Soft Packing
067	Spacer Sleeve	405	Mechanical Seal
069*	Seal Sleeve	430	Gasket
200	Ball Bearing	431	Gasket
210	Impeller Key		
211	Coupling Key		
220	Circlip		

(\*) Optional

**Material Equivalents**

Description	DIN / EN		AISI / SAE / ASTM
Cast Iron	0.6025	EN-GJL-250 (GG25)	A48 Class 40B
Nodular Cast Iron	0.7040	EN-GJS-400-15 (GGG40)	A 536 Gr. 60-40-18
Chrome Nickel Moly. Cast Steel	1.4408	GX5CrNiMo19-11-2	A351 CF8M
Chrome Steel	1.4021	X20Cr13	A276 Type 420
Chrome Nickel Steel (low carbon)	1.4404	X2CrNiMo17-12-2	A276 Type 316L

**Material Options**

Part List	10	30	70	80	7L
	0.6025	0.7040	1.4408	1.4021	1.4404
Volute Casing		●	○		
Casing Cover		●	○		
Impeller	●	○	○		
Shaft				●	○
Bearing House		●	○		
Mechanical Seal	EN 12756				

● Standard manufacturing  
○ Optional

**Flange Dimensions**

EN 1092 - 2

DNe/DNb	Suction & Discharge (PN 16)			
	Df	k	s	n
32	140	100	18	4
40	150	110	18	4
50	165	125	18	4
65	185	145	18	4
80	200	160	18	8
100	220	180	18	8
125	250	210	18	8
150	285	240	22	8
200	340	295	22	12

"n" number of holes

