



Pump • Fire Fighting Units • Booster Set

PC / PC-VM

WASTE WATER AND PROCESS PUMPS



PC / PC-VM Rev.05.03.2024



Handled Liquids

Domestic and industrial waste water, raw sewage, viscous and corrosive liquids, liquids with fibrous and solid substances.

Technical Data

Discharge Flange _____ DN 40...DN 300 mm

Capacity _____ up to 1600 m³/h

Head _____ up to 95 m

Speed _____ up to 2900 rpm

Design Temperature _____ -10 °C up to +110 °C

Casing Pressure (Pmax) _____ 10 bar (16 bar)*

(Pmax: Suction Pressure + Shut off Head)

(*) The Material of pumps differ according to the type of pumped liquid, operating temperature and pressure. Contact for detailed information.

Desing Features

•Horizontal / Vertical, wide volute casing, single stage, end suction, centrifugal pumps with enclosed, semi-open or vortex type impeller.

•18 basic sizes covering wide range of operational area.

Pump Designation

Pump Type _____

Vertical Installation _____

Discharge Nozzle (DN-mm) _____

Nominal Impeller Diameter (mm) _____

Impeller Type _____

PC -VM 250-315 AB

•Due to the back-pull-out design, the complete bearing assembly including impeller and casing cover can be dismantled without removing the volute casing from the pipe system. (With spacer coupling application, also possible to take out the rotor group without dismantling the electric motor.)

•Discharge flanges conform to EN 1092-2 / PN 10.

•All impellers are balanced dynamically or statically according to ISO 1940 class 6.3.

•Axial thrust is balanced by impeller back ribs.

•Direction of rotation is clockwise viewed from drive end.

•Bearings of PC type pumps are "life time grease lubricated" ball bearing up to 150-315 size. For bigger sizes oil lubricated bearings are used. In vertical design (PC-VM) always grease lubricated bearings are used.

Shaft Sealing

•In standard production soft packed stuffing boxes are used.

•Depending on customer request, mechanical seals are available. In this case, pump shaft is always stainless steel.

•Only mechanical seal is applied for vertical type installation.

B Type Impeller: Enclosed type impellers with wide channels capable of pumping large size solid particles without clogging, for big capacity and low pressure. It is mainly used for 4 pole motors.

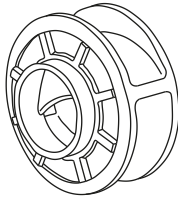

D Type Impeller: It is also enclosed type like B type but suitable for high speed motors (2 pole). It is convenient for high pressure, small capacity and smaller size solid particles.

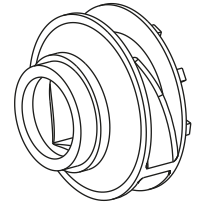

VX Type Impeller: Semi-open free vortex type impeller is placed on top of the volute. It creates a forced vortex motion in the casing. It is mostly suitable for fibrous materials. They are suitable for low head applications but pump efficiency is lower compare to other impeller types. The increased clearances limit the head that can be generated and reduce the attainable efficiency. Recessed type impellers are also possible for some models. With this type of design solid particles up to pump flanges size can pass through the pump. Please ask for more information.

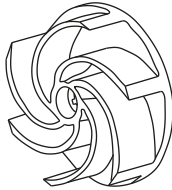

AB Type Impeller: Semi-open type impellers with wide channels capable of pumping large size solid particles without clogging, for big capacity and low pressure. It is more suitable for 4 pole motors. Designed for aggressive applications. Impeller works against a wear plate. Clearance between the wear plate and impeller blades is between 0.25 - 0.40 mm.

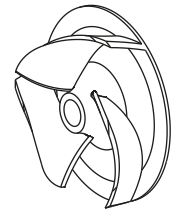

Field Chart

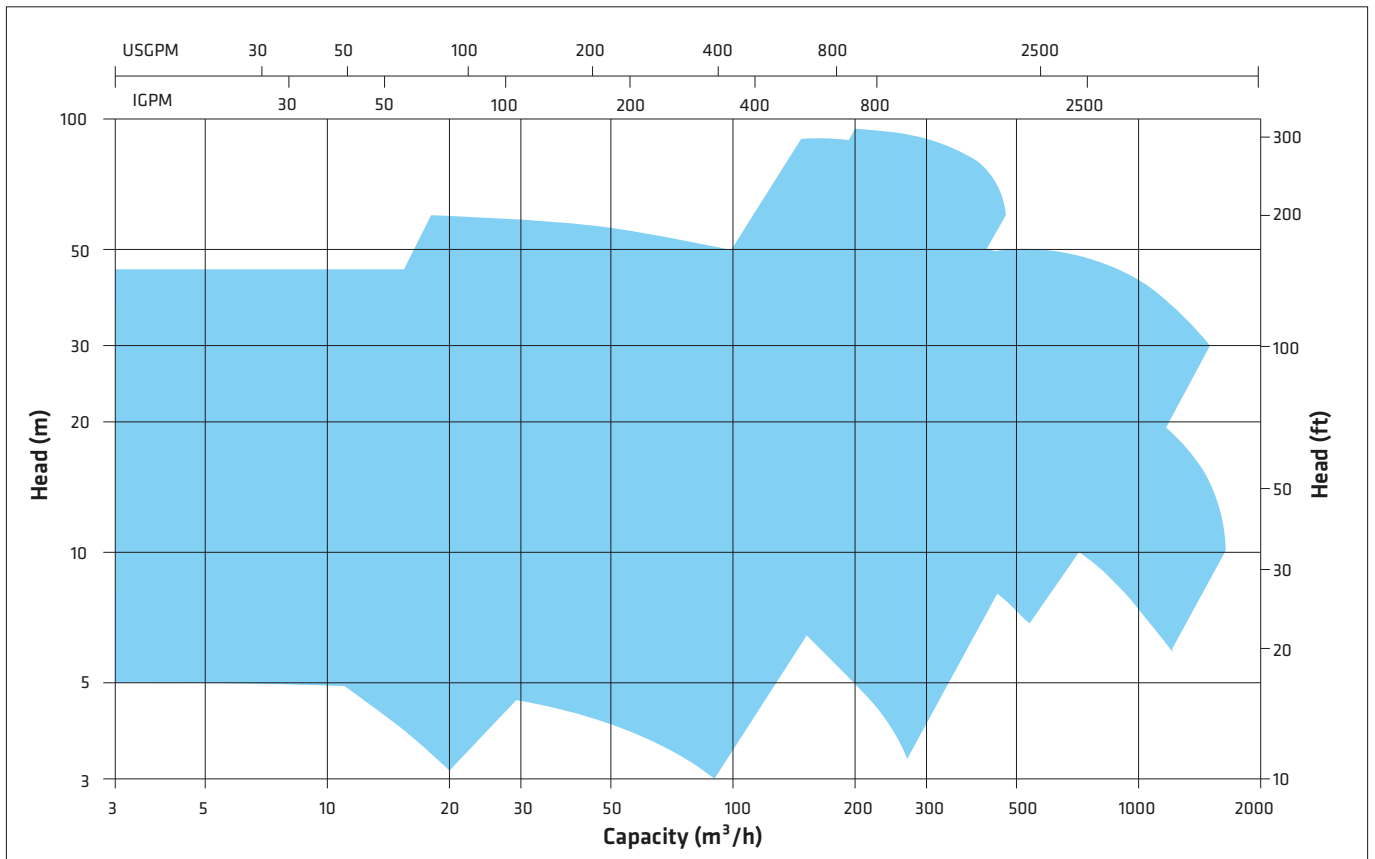

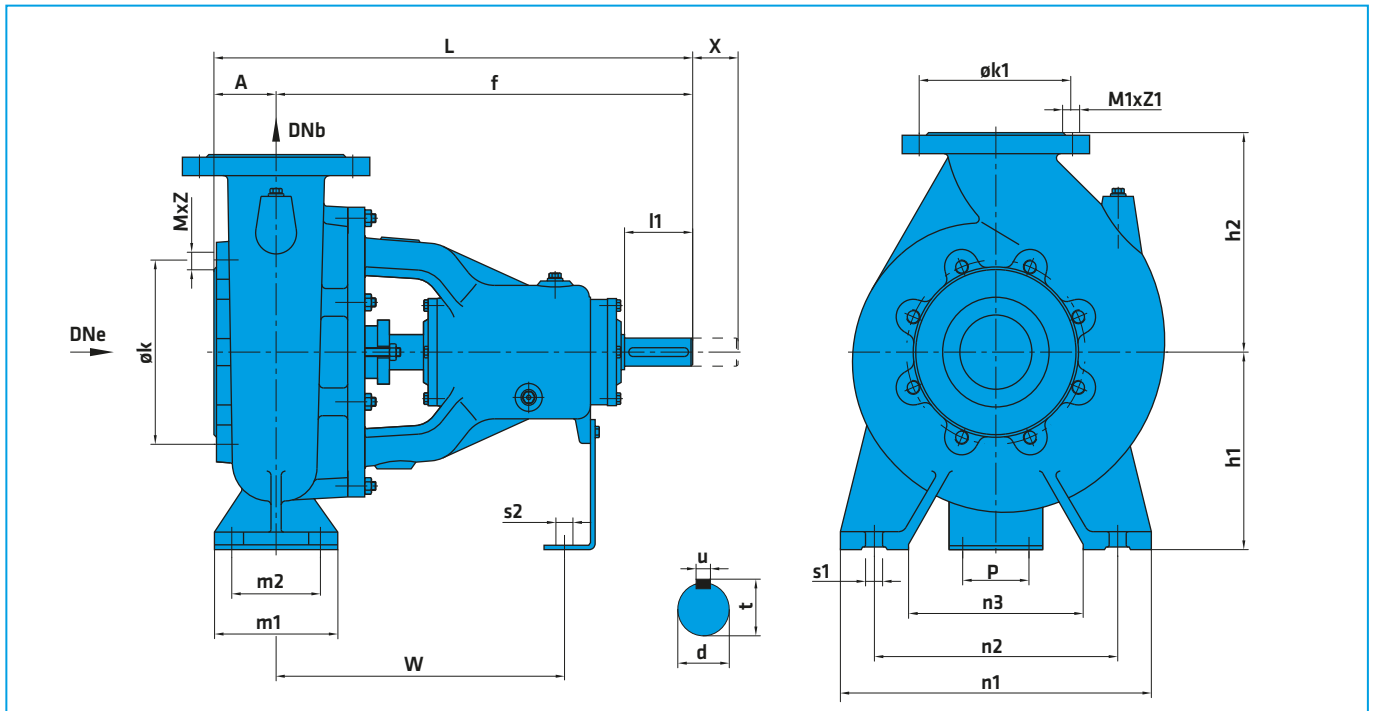

Pump Type	DN		Overall Dimensions (mm)				Support & Foot Dimensions (mm)						Shaft (mm)				Flange Dimensions Suction		Flange Dimensions Discharge		Weight (kg)					
	DNc	DNb	A	f	L	h1	h2	m1	m2	n1	n2	n3	s1	P	s2	W	d	l1	t	u		x(**)	k	MxZ	k1	M1xZ1
40-160	50	40	82	348	430	160	180	100	70	240	190	140	14	110	14	247	24	50	27	8	140	125	M16x4	110	18x4	50
50-160	65	50	100	350	450	160	180	100	70	270	212	160	14	110	14	270	24	50	27	8	140	145	M16x4	125	18x4	50
50-200	65	50	105	370	475	160	200	100	95	270	210	160	14	110	14	270	24	50	27	8	140	145	M16x4	125	18x4	60
65-200	80	65	108	372	480	180	225	125	95	330	255	190	14	110	14	260	24	50	27	8	140	160	M16x8	145	18x4	65
80-160	100	80	83	384	467	180	180	120	85	310	250	190	14	110	14	288	24	50	27	8	140	180	M16x8	160	18x8	60
80-200	100	80	83	488	571	180	220	125	90	350	280	215	18	110	14	358	32	80	35	10	140	180	M16x8	160	18x8	70
80-315	100	80	55	480	535	250	310	125	95	400	315	240	18	110	14	350	32	80	35	10	140	180	M16x8	160	18x8	75
100-240	125	100	82	492	574	225	250	160	110	370	280	205	20	110	14	357	32	80	35	10	140	210	M16x8	180	18x8	100
100-270	125	100	97	500	597	275	310	160	110	430	345	270	20	110	14	371	32	80	35	10	140	210	M16x8	180	18x8	110
100-315	125	100	97	500	597	275	310	160	110	430	345	270	20	110	14	371	32	80	35	10	140	210	M16x8	180	18x8	120
150-315	150	150	119	638	757	280	355	200	150	500	400	300	23	110	14	445	42	110	45	12	200	240	M20x8	240	23x8	170
150-500	150	150	126	782	908	425	600	250	200	720	600	435	28	140	20	562	55	110	59	16	200	240	M20x8	240	23x8	580
200-315	200	200	165	707	872	355	450	250	200	600	500	360	24	110	14	543	48	110	51	12	250	295	M20x8	295	23x8	315
200-400	200	200	142	757	899	380	530	250	200	600	500	360	24	140	20	536	55	110	59	16	250	295	M20x8	295	23x8	370
200-500	150	200	126	968	1094	425	600	300	240	720	580	435	28	140	20	700	70	140	74,5	20	170	240	M20x8	295	23x8	600
250-315	200	250	145	1003	1148	335	475	300	230	680	540	400	27	140	20	730	70	140	74,5	20	265	295	M20x8	350	23x12	430
300-400	300	300	201	974	1175	400	560	300	240	720	600	435	27	140	20	730	75	140	79,5	20	285	400	M20x12	400	23x12	675
300-500	300	300	201	974	1175	450	600	300	230	800	660	520	27	140	20	700	75	140	79,5	20	300	400	M20x12	400	23x12	750

(*) Dimensions may differ according to bearing housing type (normal, heavy duty etc). We have rights to make change with the dimensions.

(**) Gap necessary for the withdrawal of the pump rotor from the driven end without the need for disconnecting the motor and pipework (spacer coupling application).

Horizontal Installation (PC)

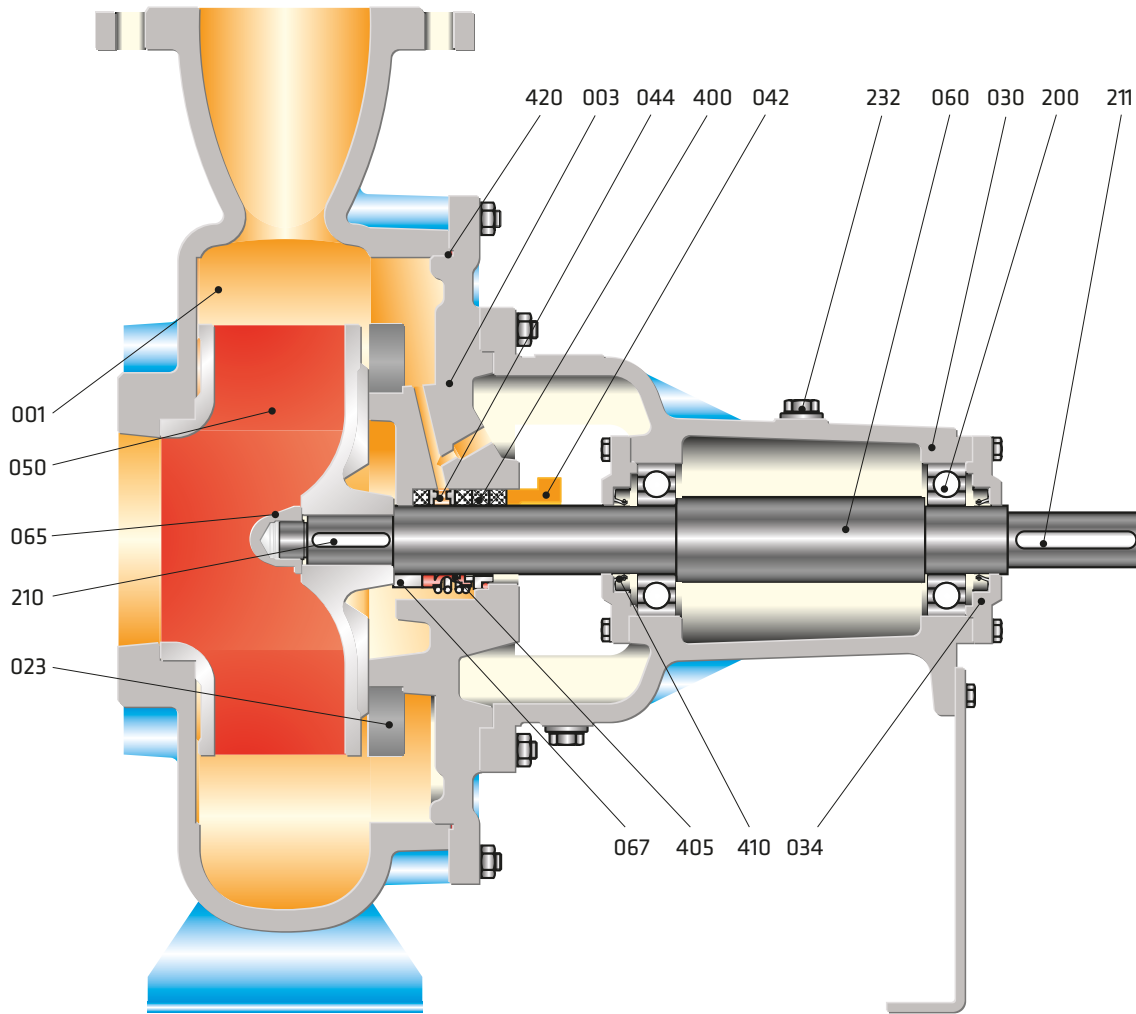

Semi-Open Impeller Application

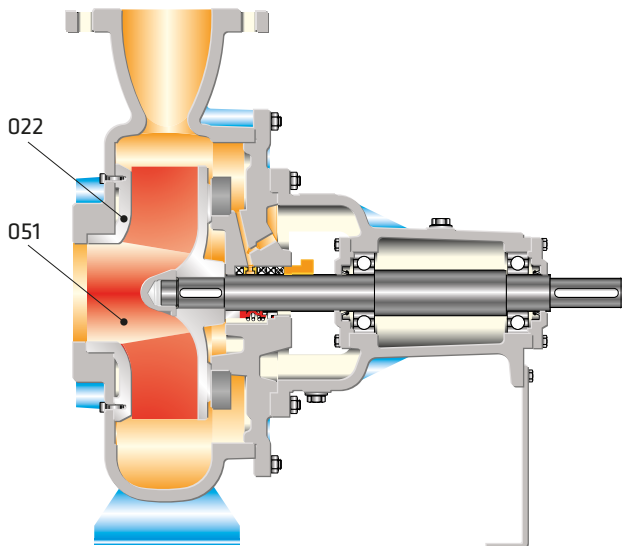

Heavy Duty Type Bearing Application

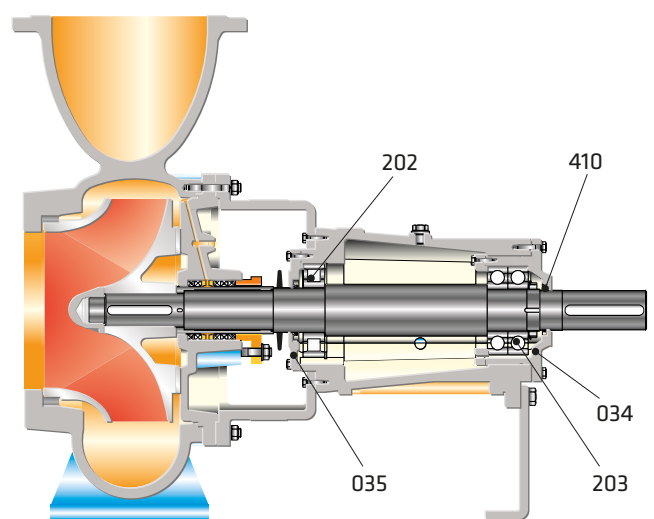

Vertical Installation (PC-VM)

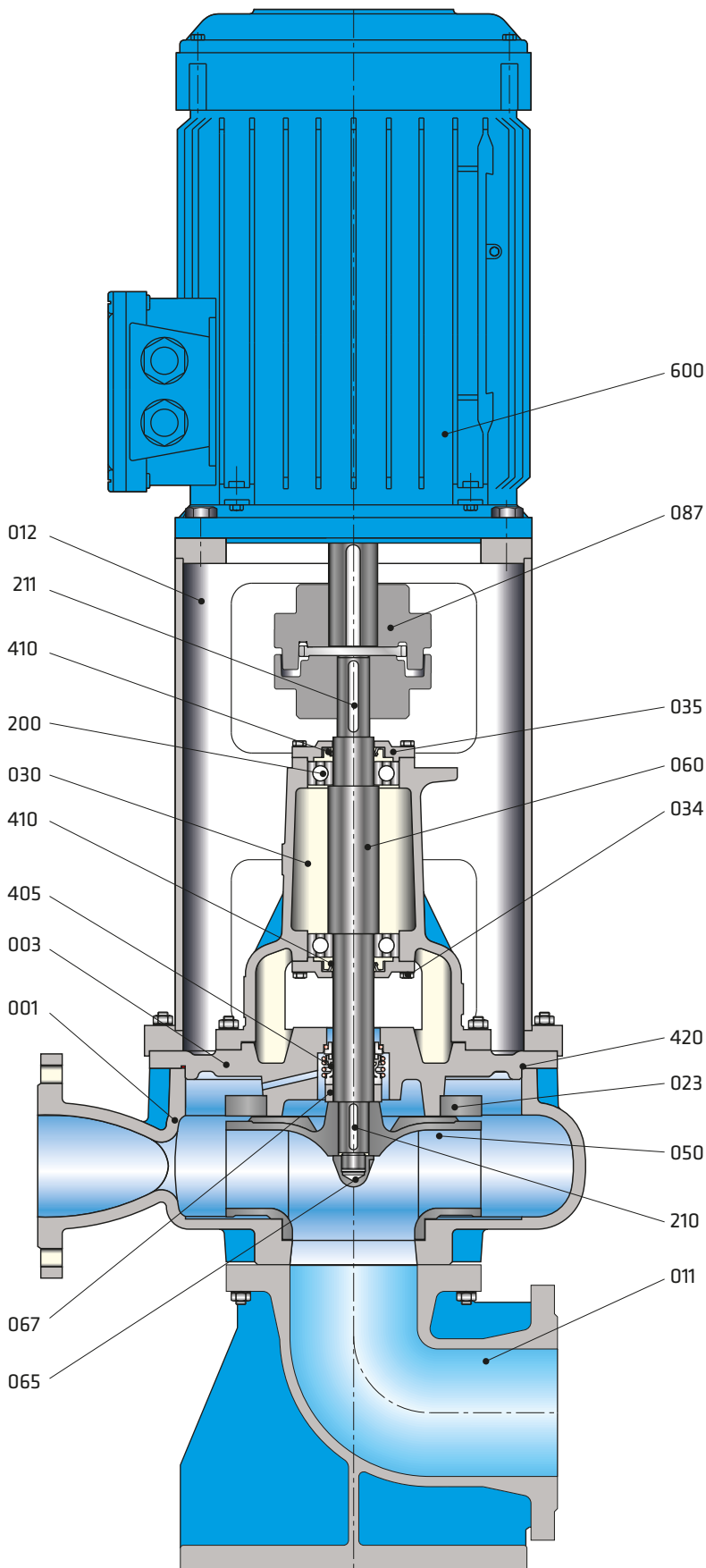

Part List

001	Volute Casing
003	Casing Cover
011	Elbow Foot
012	Motor Pedestal
022	Front Wear Plate
023	Back Wear Plate
030	Bearing Housing
034	Bearing Cover
035	Bearing Cover
042	Gland
044	Lantern Ring
050	Impeller
051	Semi-Open Impeller
060	Pump Shaft
065	Impeller Nut
067	Spacer Sleeve
087	Flexible Coupling
200	Ball Bearing
202	Roller Bearing
203	Angular Contact Ball Bearing
210	Impeller Key
211	Coupling Key
232	Oil Filling Plug
400	Soft Packing
405	Mechanical Seal
410	Lip Seal
420	O-Ring
600	Electric Motor

PART LIST	0.6025	0.7040	0.7043	1.0619	1.4308	1.4309	1.4408	1.4409	1.4500	1.4517	1.4469	1.4317	1.4008	2.1050.01	2.0975.01	2.1096.01	1.0503	1.4021	1.4021+QT	1.4301	1.4404	1.4460	1.4462	
Volute Casing	●	○	○	○	○	○	○	○	○	○	○	○	○	○										
Casing Cover	●	○	○	○	○	○	○	○	○	○	○	○	○	○										
Impeller	●	○	○	○	○	○	○	○	○	○	○	○	○	○	○	○							○	
Shaft																	●	○	○	○	○	○		○
Bearing Housing	●	○	○	○	○	○	○	○																
Front Wear Plate	○	○	○	○	○	○	○	○	○	○	○	○	○	○	○	○								
Back Wear Plate	●	○	○	○	○	○	○	○	○	○	○	○	○	○	○	○								
Spacer Sleeve																	●	○	○	○	○			○

Depending on customer requirement or request different types and brands of mechanical seals are applicable.

● Standard manufacturing
○ Optional

Material Equivalents

Description	DIN / EN		AISI / SAE / ASTM
Cast Iron	0.6025	EN-GJL-250 (GG25)	A48 Class 40B
Nodular Cast Iron	0.7040	EN-GJS-400-15 (GGG40)	A536 60-40-18
Nodular Cast Iron	0.7043	EN-GJS-400-18-LT (GGG40.3)	A536 60-40-18
Cast Steel	1.0619	GP240GHGS-C25	A216 WCB
Chrome Nickel Cast Steel	1.4308	GX5CrNi19-10	A351 CF8
Chrome Nickel Cast Steel (low carbon)	1.4309	GX2CrNi19-11	A351 CF3
Chrome Nickel Molybdenum Cast Steel	1.4408	GX5CrNiMo19-11-2	A351 CF8M
Chrome Nickel Molybdenum Cast Steel (low carbon)	1.4409	GX2CrNiMo19-11-2	A351 CF3M
Austenitic Cast Steel	1.4500	GX7NiCrMoCuNb25-20	A351 CN7M
Austenitic - Ferritic Cast Steel (duplex)	1.4517	GX2CrNiMoCuN25-6-3-3	A890 CD4MCuN
Austenitic - Ferritic Cast Steel (super duplex)	1.4469	GX2CrNiMoN26-7-4	A890 CE3MN
Martenzitic Stainless Cast Steel	1.4317	GX4CrNi13-4	A352 CA6NM
Martenzitic Stainless Cast Steel	1.4008	GX7CrNiMo12-1	A217 CA15
Cast Bronze (tin alloy)	2.1050.01	G-CuSn10	B427 C90700
Cast Bronze (nickel alloy)	2.0975.01	G-CuAl10Ni	B148 C95500
Cast Bronze (lead)	2.1096.01	G-CuSn5ZnPb	B584 C83600
Carbon Steel	1.0503	C45	AISI 1045
Chrome Steel	1.4021	X20Cr13	A276 Type 420
Chrome Steel (heat treated)	1.4021	X20Cr13	A276 Type 420+QT
Chrome Nickel Steel	1.4301	X5CrNi18-10	A276 Type 304
Chrome Nickel Steel (low carbon)	1.4404	X2CrNiMo17-12-2	A276 Type 316L
Duplex (austenitic-ferritic) Steel	1.4460	X3CrNiMoN27-5-2	AISI 329
Duplex (austenitic-ferritic) Steel	1.4462	X2CrNiMoN22-5-3	UNS S32205

Flange Dimensions

EN 1092 - 2

DNe/DNb	Suction & Discharge (PN 10)			
	Df	k	s	n
40	150	110	18	4
50	165	125	18	4
65	185	145	18	4
80	200	160	18	8
100	220	180	18	8
125	250	210	18	8
150	285	240	22	8
200	340	295	22	8
250	395	350	22	12
300	445	400	22	12

" n " number of holes

The drawing shows a side view of a flange with dimensions Df (total thickness), k (flange thickness), and DNe/DNb (inner diameter). The top view shows a circular flange with a central hole and 'n' smaller holes around the perimeter, with 's' representing the hole spacing.