



Pump • Fire Fighting Units • Booster Set



PACKAGE TYPE WASTE WATER PUMPING STATION

Conflux Rev.05 03.2024



Package Type Waste Water Pumping Station

Package type waste water pumping stations consist of submersible pump, valves, float switches and control unit is suitable and a good solution for places with lower elevation of main waste water pipeline. They can be used everywhere safely where there is no sewer system or not possible (not economic) to build a sewer system.

They present an environmental approach with preventing pollution of underground waters. They also prevent developing of malodor. Their design permit easy installation and provide long life with corrosion resistant materials.

Technical Data

- Tank Volume : 300 - 500 liter
- Number of Pumps : 1 main or 1 main + 1 spare
- Piping Diameter : DN 50
- Material : Fiberglass composite with polyester added
- Equipments : Connection pipes, rail pipes, valves, check valve and çekvalfleri, basket grid
- Water Temperature (max) : 40 °C

Package Types



Conflux 300-1



Conflux 300-2



Conflux 500-2

Pump Designation

Conflux 500 - 2 x 1.5 - 50

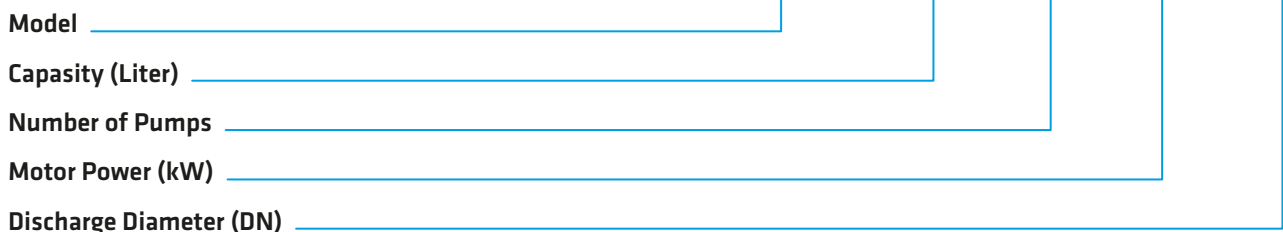

Dimensions

Conflux 300-1

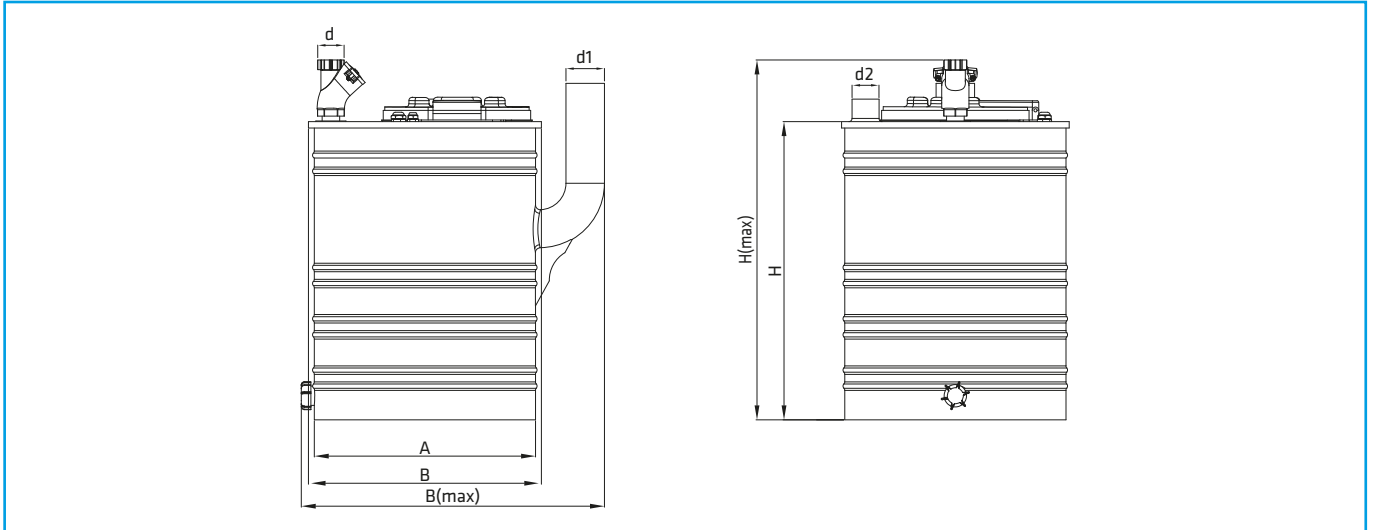

Conflux 300-2

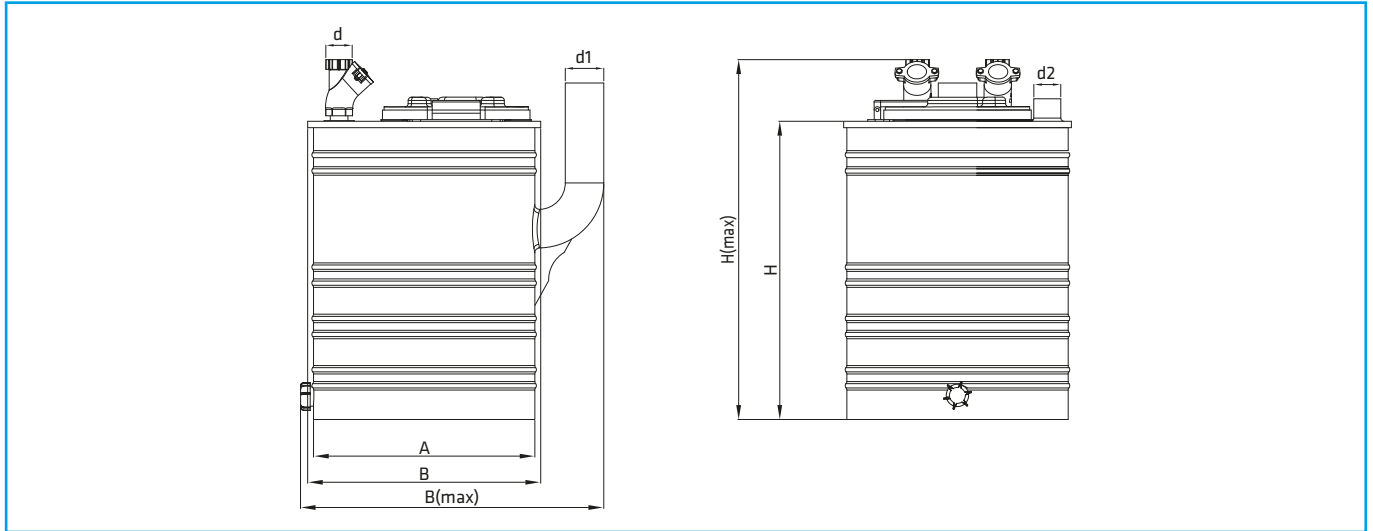

Conflux 500-2

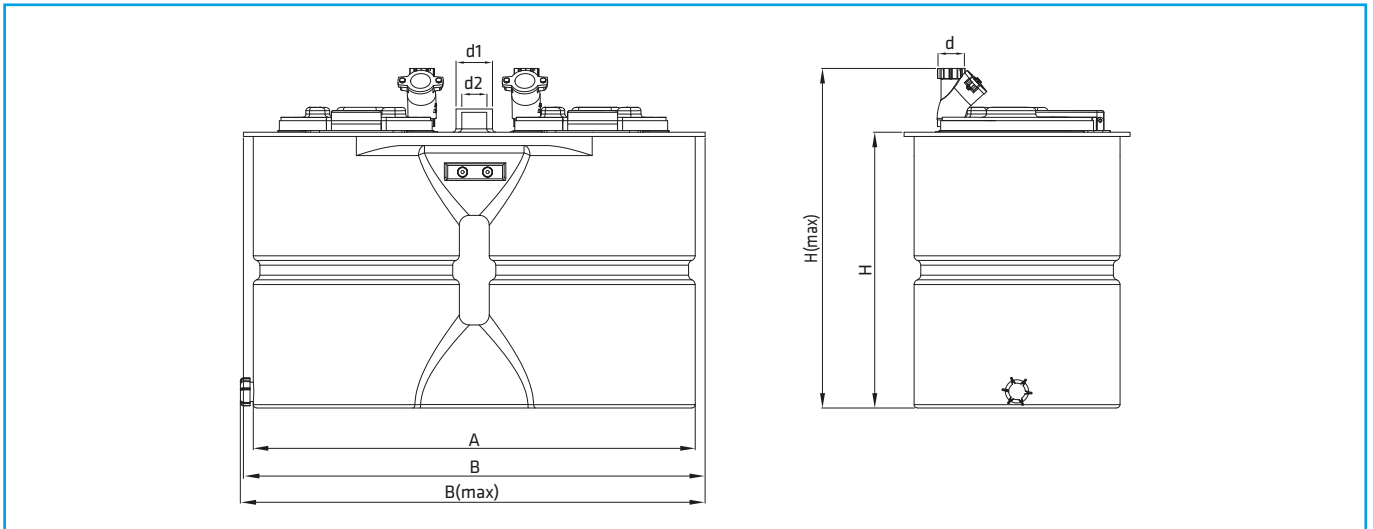

Package Type	Conflux Dimension Table							
	A	B	B(max)	H	H(max)	d	d1	d2
Conflux 300-1	690	710	950	930	1125	2"	4"	3"
Conflux 300-2	690	710	950	930	1125	2"	4"	3"
Conflux 500-2	1330	1390	1400	830	1025	2"	4"	3"